

CUSEC

**Central United States
Earthquake Consortium**

2630 E. Holmes Rd., Memphis, TN 38118 (910)544-3570



Nonstructural Earthquake Hazards and Nursing Homes

What Are Nonstructural Hazards?

Overturning file cabinets or shelving or hazardous materials falling off shelves and spilling are examples of nonstructural earthquake hazards. These hazards are distinct from damage to the structure-- the columns, beams, load-bearing walls, and floors that support a building.

The purpose of this brochure is to provide practical advice on making physical changes to nonstructural conditions--anchoring or changing the location of furnishings, for example--and to offer related emergency planning guidance.

Special Considerations In Nursing Homes

The occupants of a nursing home may need extra help in protecting themselves during the shaking and coping afterward. On the positive side, however, most nursing homes have fewer nonstructural hazards than offices, hospitals, or commercial buildings.

Earthquake Engineering Rules of Thumb

The following simplified principles can help non-engineers figure out which nonstructural items are hazardous.

The more an object weighs, the more forcefully it moves in an earthquake. A water heater weighing 400 pounds requires much stronger restraint than a lightweight bookshelf unit.

The more slender the object, the more likely it is to tip over. Objects at least one and one-half times taller than their narrowest base dimension are the most likely to tip over in earthquakes. Thus a four-drawer

file cabinet will be more likely to overturn than a stockier two-drawer model when they are shaken.

The higher the object, the greater the hazard. An object such as a heavy aquarium on a shelf four feet off the floor is a greater hazard than the same item located on a shelf only two feet high.



Television sets on elevated shelves must be securely restrained: the television bolted to the shelf or bracket, and the shelf properly anchored to the wall.

An anchorage or restraint is only as strong as its weakest link. Anchoring cabinets, shelving, etc. securely to the wall is a common solution to the hazards posed by furnishings. But if the connection is made to the finish material of the wall, typically the plaster or drywall (gypsum board), the toggle bolt or plastic sleeve can easily fail. Connections should be made directly to the wall structure: the 2x4 studs in wood

CUSEC is a partnership of the Federal Emergency Management Agency and the States of Alabama, Arkansas, Illinois, Indiana, Kentucky, Mississippi, Missouri, and Tennessee

frame construction, metal studs in many commercial or institutional buildings, or concrete or masonry walls. Lag screws a quarter inch in diameter and long enough for the threads to penetrate two inches into the 2x4 are often specified by engineers for the common case of wooden studs.

A rough test of the adequacy of a restraint: You should be able to pull horizontally on the object with a force equal to its weight. This takes into consideration safety factors.

The most reliable hazard evaluations and solutions are engineered. You may be able to obtain some engineering expertise from consulting engineers and architects in your area for a small cost. Also consider surveying patient relatives to see if any have relevant skills in the fields of architecture, engineering, or building construction.

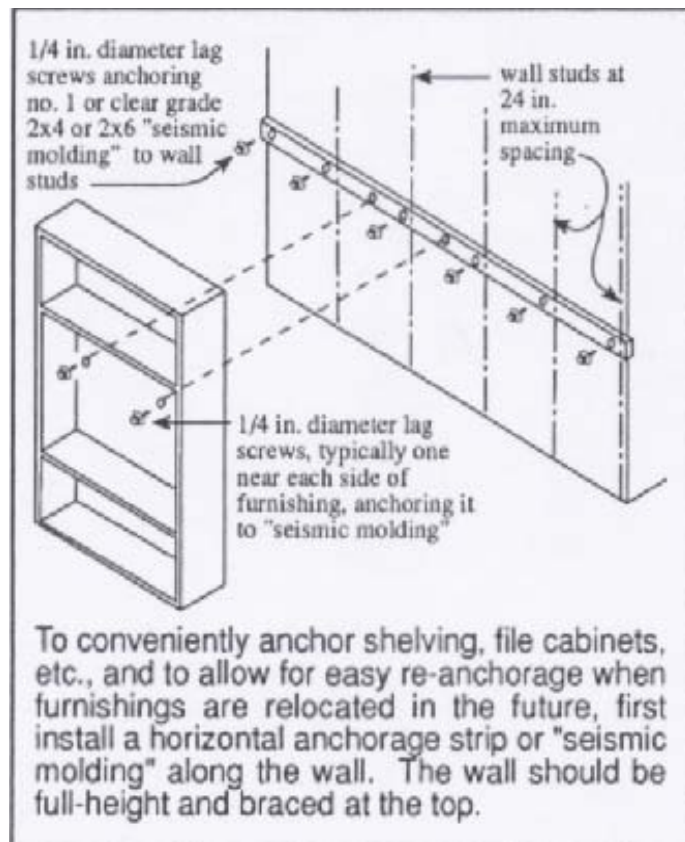

Emergency Planning

The standard "what to do during an earthquake" advice is to get under a desk, table, countertop, etc. and cover your head, but many nursing home occupants would find this difficult to quickly do. The most hazardous position for a patient is standing up. Lying down in

bed, sitting down on a chair or in a wheelchair, or quickly sitting or kneeling on the floor offers more safety simply because there is less chance of falling. Thus, for nursing home patients, perhaps the best advice is to simply sit down (on the floor, unless a chair is immediately at hand) if standing or walking when the shaking starts, and the next best thing is to hold onto a rail or other support.

After the shaking has stopped, the first task is to check to see if anyone is injured and needs help.

Count on a telephone outage. This means you should have a back-up plan for sending messages such as requests for medical help. Have a street map of your area with the nearest always-open emergency facility (typically the nearest fire station) clearly indicated, along with your location. After an earthquake, you could send someone for help on foot or by car with the accurate directions of this map.

Quickly check the building for any major damage. The one best rule of thumb for non-engineers concerning structural damage is that if the building is leaning noticeably, it should be considered unsafe and everyone should exit.

Distinguishing between structural and nonstructural damage is important. In one earthquake in Southern California in 1987, some of the lightweight suspended ceiling fell down, but there were no injuries. This "collapse" of a nonstructural feature of the building was mis-reported as the "collapse of the roof" in television news accounts, causing undue concern on the part of relatives and friends.

Know where shut-off valves or switches are for the gas or fuel oil, water, and electrical systems. Shut off a system only if there is obvious damage or you detect a leak or short circuit.

Contact the American Red Cross, a local hospital, or your local fire department for first aid courses for parents and staff. First Aid/CPR training can pay off in many possible emergencies, not just earthquakes.

Utility outages are common following earthquakes, and therefore important emergency supplies include flashlights with extra batteries and battery-operated radios, a supply of drinking water, and blankets.

Nonstructural Safety Checklist

This list is not all-inclusive but it does itemize the more common hazards. Deal with the most likely or potentially serious conditions first. The following checklist has been adapted from "Checklist of Nonstructural Earthquake Hazards in Child Care Facilities, produced by The Reitherman Company for the Southern California Earthquake Preparedness Project of the California Office of Emergency Services in 1990.

EQUIPMENT AND FURNISHINGS

- ▣ **File Cabinets:** Are tall cabinets, approximately taller than desk height, secured to prevent overturning? As a second choice, cabinets should be bolted to each other to make a more stable or stocky combined shape. A stockier shape (wider footprint) makes an object less likely to overturn, and this technique could be considered partial protection. Teachers should be encouraged to place file cabinets against walls where facilities personnel could anchor them.
- ▣ **Shelving:** Are units securely attached to the wall?
- ▣ **Shelf Contents:** Heavy or sharp items are stored on shelves that have lips, elastic cords, or are sloped slightly backward.
- ▣ **Television Sets, Computers:** Are these pieces of equipment restrained so they won't fall? Sturdy brackets are available for wall mounted TVs and are often used in used in hospitals and nursing homes. In addition to attaching the bracket to the wall, the TV must be bolted to the bracket.
- ▣ **Storage Cabinets:** Are tall cabinets secured to the wall, and are their doors latched?
- ▣ **Wall Hangings:** Are heavy or potentially sharp wall decorations securely mounted
- ▣ **Hazardous Materials:** Are laboratory chemicals or cleaning supplies secured so that they won't fall and spill? Are essential medicines similarly protected, especially if in glass containers?
- ▣ **Pianos, Heavy Carts:** Are heavy furnishings or equipment on wheels latched or tethered to the wall when "parked"?
- ▣ **Fire Extinguishers:** Are fire extinguishers secured so they won't fall off a wall bracket if they swing or jiggle during an earthquake?
- ▣ **Refrigerators:** Are tall refrigerators secured or prevented from tipping by built-in cabinetry above?

OVERHEAD ELEMENTS

- ▣ **Suspended Ceiling Components:** In non-residential buildings with hung ceilings, does the ceiling have diagonal bracing wires? More importantly, are any light fixtures, air diffusers, or speakers resting on the suspended ceiling gridwork provided with the back-up support of two safety wires at diagonally opposite corners?
- ▣ **Pendant Light Fixtures:** Do light fixtures that are supported by stems (metal conduit or "pipe" about an inch in diameter) have safety wires extending up through the stem or otherwise attached to the fixture?
- ▣ **Spot Lights, Track Lights:** Are lights securely mounted so that when the fixtures shake they won't come off and fall?
- ▣ **Suspended Space Heaters:** Are these heaters, especially if supplied with natural gas, hung with vertical rods that also have diagonal bracing?
- ▣ **Hanging Plants and Displays:** If heavy, are they attached to the structure above rather than just to plaster, sheetrock, or a suspended ceiling's gridwork? Are closed eye-screws rather than open hooks used?
- ▣ **Battery-powered Emergency Lights:** Are these units secured to shelves or brackets?
- ▣ **Projection Screens:** Are these ceiling or wall mounted items securely fastened?
- ▣ **Compressed Gas Cylinders:** Are large cylinders of oxygen or other gas secured properly with two strong and tight chains, one near the top and the other toward the bottom, or the equivalent?

MECHANICAL EQUIPMENT

- ▣ **Water Heaters:** Are water heaters restrained rigidly with bracing or metal strapping? (Water or gas pipe connections do not "count" as earthquake bracing). Flexible pipe connectors are desirable.
- ▣ **Furnaces, Heaters:** Are furnaces restrained so that

they won't slide and break gas or electrical lines?

- ▣ **Heating-Ventilating-Air Conditioning Ducts:** Do large sheet metal ducts have diagonal bracing above or do they have enough vertical straps to keep any section from falling if the ductwork separates into sections? Any diffusers or grills, unless screwed to a rigid duct, should have their own back-up support wires to the structure above.

PARTITIONS

- ▣ **Shelving-As-Room-Divider:** Are lightweight panels, rather than shelving units or other tall furnishings used to divide up a room?
- ▣ **Freestanding Partitions:** Are room dividers that are heavy (heavier than "bulletin board" panels) and that extend partway to the ceiling braced by interconnecting them in L-shaped or zigzag layouts?
- ▣ **Partitions Anchoring Shelving or Cabinets:** Do partitions that extend only as high as the suspended ceiling have braces or other support to the structure above if they are used to anchor heavy objects?

WINDOWS

- ▣ **Large Panes:** Are large panes safety-glazed? If made of safety glass, typically tempered glass, there will be a small white-lettered label in a corner of each pane; in recent construction, usually all glass within 18 inches of the floor or in doors is safety glazed
- ▣ **Transoms:** Arc transoms (window panes located over doorways) safety glazed?
- ▣ **Glazed Partitions:** Do partitions have plastic or safety glass panels, rather than ordinary glass?

EXTERIORS

- ▣ **Fences:** Were tall fences that arc made of concrete, concrete block, stone, or brick, constructed with adequate steel reinforcing for earthquake resistance? (The steel is hidden inside; verifying earthquake resistance requires knowing how the walls were built).
- ▣ **Gas, Electrical, and Water Shut-offs:** Is the location and method of operation known to the staff, diagrammed in a "what to do in case of emergency" notice, and is any necessary wrench in place?

- ▣ **Trees:** Have trees that were leaning or in poor health been trimmed or removed?

SOURCES OF INFORMATION

CUSEC can provide information on a variety of earthquake related topics. Visit www.cusec.org, or call the phone number listed on page 1.

State and Local Agencies may be able to provide useful information. Check with your office of emergency services (emergency management, disaster services, civil defense), building inspection or building code department, planning department, and fire department. Contact your state emergency management agency for information on attending the two-day FEMA course on *Nonstructural Earthquake Hazard Mitigation for Hospitals and other Health Care Facilities*. For extended care operations housed in tall buildings, there is another FEMA course on *Earthquake and Fire Hazards in High-Rise Buildings*.

Federal Emergency Management Agency, Phone: 1-800-621-FEMA or Online: www.fema.gov FEMA publishes FEMA Publication 74, *Reducing The Risks of Nonstructural Earthquake Damage: A Practical Guide* and FEMA 75, *Preparedness for People with Disabilities*, and FEMA 150, *Seismic Considerations of Health Care Facilities*. Other Earthquake Hazards Reduction publications available upon request.

Earthquake Engineering Research Institute, Phone: (510) 451-0905 or Online: www.eeri.org EERI has a slide set on *Nonstructural Earthquake Damage*. Order forms for other publications and audiovisual materials also available.

Disclaimer

Professional expertise is recommended to increase the probability that intended levels of earthquake protection will be achieved. No guarantee is made that following the guidance in this publication will prevent all earthquake damage. Liability for losses that are caused by an earthquake or as a result of using this publication is specifically disclaimed.

This brochure funded by the Federal Emergency Management Agency: Grant Number L-EMW-2004-CA0428